

Wireless Remote Fire Gas Gun with TAM Software Operating Manual



ECHOMETER COMPANY

5001 Ditto Lane
Wichita Falls, Texas, USA
Phone: (940) 767-4334
Email: info@echometer.com
Website: www.echometer.com

Table of Contents

Introduction	1
Limits of Liability	1
Copyright Notice	1
Safety Considerations	2
Description and Operation	3
General Operation Procedures	4
Maintenance and Troubleshooting Guide	13
Recommended Procedures to Minimize Equipment Maintenance	13
Maintenance Procedures	15
Wireless Remote Fire Gas Gun Drawing with Part Numbers	19
Troubleshooting Proper Sensor Function	20
LED Behavior on Sensors or Base Station.....	23
Troubleshooting Interference or Poor Signal	25
Installing Device Driver for Hardware.....	27
Carbon Dioxide and Nitrogen Information	28

Echometer Wireless Remote Fire Gas Gun



Wireless Acoustic Wellhead Attachment

Introduction

This operating manual contains information about the Echometer Wireless Remote Fire Gas Gun including installation instructions, operating procedures, maintenance and troubleshooting, acquiring data on problem wells, record interpretation and technical references relating to the optimization of producing wells. Please read the manual before operating the instrument. Additional technical papers can be accessed from the Echometer Web page, www.echometer.com; these articles offer additional information on the use of acoustic fluid level instruments to optimize production. Please read these papers at your convenience.

Limits of Liability

Echometer Company reserves the right to revise its software and publications with no obligation of Echometer Company to notify any person or any organization of such revision. In no event shall Echometer Company be liable for any loss of profit or any commercial damage, including but not limited to special, consequential, or other damages.

Information in this document is subject to change without notice and does not represent a commitment on the part of Echometer Company. The software described in this document is furnished under a license agreement or nondisclosure agreement. It may be used or copied only in accordance with the terms of the agreement. It is against the law to copy the software or any medium except specifically allowed in the license or non-disclosure agreement.

Copyright Notice

Copyright 2015 Echometer Company. All rights reserved. Federal copyright law protects this manual. No part of this manual may be copied or distributed, transmitted, transcribed, stored in a retrieval system or translated into any human or computer language, in any form or by any means, electronic, mechanical, magnetic, manual, photographic, photocopy, scanning, or otherwise, or disclosed to third parties without the express written permission of Echometer Company.

Trademarks

TAM, TWM, AWP, QRod, Wireless Remote Fire Gas Gun are trademarks of Echometer Company

Safety Considerations

Read this manual before operating the equipment.

Please observe all safety rules in operating this equipment. The pressure ratings of the Echometer gas gun and all fittings, hoses, etc. should always exceed actual well pressure. Because the wellhead pressure normally increases during a build-up test, caution should be exercised that the well pressure does not exceed equipment pressure ratings.

Do not use worn or corroded parts. A used or corroded fitting may not withstand original pressure rating.

All safety precautions cannot be given herein. Please refer to all applicable safety manuals, bulletins, etc. relating to pressure, metal characteristics, temperature effects, corrosion, wear, electrical properties, gas properties, etc. before operating this equipment.

The tests should not be undertaken if the operator, the test equipment and the well are not in conditions to operate safely. This equipment should not be used if the operator is tired, ill or under the influence of alcohol, drugs or medication.

Description and Operation – Wireless Remote Fire Gas Gun

The Wireless Remote Fire Gas Gun (WRFG) is a self-contained acoustic fluid level data acquisition/transmission instrument. The Wireless Remote Fire Gun generates an acoustic pulse by remote fire from a computer located in a safe area, or by utilizing function buttons located on the gas gun itself. The generated acoustic pulse is accomplished by loading the volume chamber with compressed gas to a pressure greater than the wellbore. A rapid discharge of the compressed gas delivers the acoustic pulse to the well. A microphone housed in the gas gun detects the shot, collars and other wellbore reflections, and liquid level echo. A pressure transducer located within the gas gun measures wellhead pressure and temperature. A data acquisition and wireless transmission system records and transmits the initial impulse, subsequent acoustic reflections, and measurements for processing in a computer located in a safe area.



The serial number of the Wireless Remote Fire Gun consists of the letters WR followed by three digits. For example: WR123.

The standard unit is manufactured entirely with 316 stainless steel and has a working pressure of 1500 PSI. It has been hydrostatic tested to 3000 PSI. Note: The thread protector is not stainless 316.



General Operation Procedures

The Wireless Remote Fire Gas Gun (WRFG) should be attached to the casing annulus or tubing head, and wireless communication between the gas gun and the Base Station via the TAM software should be established. The valve between the casing annulus or tubing and the flow line should be closed to prevent the well gas from venting into the flow line causing excessive noise. The gas gun volume chamber is filled with compressed gas. The pressure gauge on the gun is used to determine when the volume chamber is filled to a pressure in excess of the well pressure before opening the casing valve. Before firing the shot, the gas gun bleed valve should be closed, and the valve between the gun and the wellhead opened. A quick release of gas into the wellbore delivers an acoustic pulse to the well gas. A vibration-canceling dual-disk microphone detects the shot and the reflected pulses. An accurate strain gauge pressure transducer electronically indicates temperature and casing or tubing pressure. The acquired acoustic, temperature and pressure measurements are transmitted wirelessly to the Base Station that is connected to the laptop, and are displayed by the TAM software. When acquisition of data at the well is complete, the wellhead valves are returned to their original position, pressure between the WRFG and the closed casing valve is relieved using the WRFG bleed valve, and the gas gun is removed from the well. The following sections illustrate in detail a mode of operation of the instrument and software assuming the fluid level measurements are performed in the casing annulus of a producing well.

Operation of the Wireless Remote Fire Gas Gun

The Wireless Remote Fire Gas Gun is designed to be operated only in the EXPLOSION (Compression) mode.

Steps to Shoot a Fluid Level

<p>Establish communication between the Base Station (Wireless Well Analyzer) and the Laptop.</p> <ol style="list-style-type: none">1. Turn on the Laptop.2. Start the TAM software.3. Plug the USB cable into the Laptop.	
<p>Setup Hardware in TAM will display “No Sensors Connected” in green when communication is made.</p> <p>Clicking the Setup Hardware button will bring up the Setup Hardware window.</p> <p>A green checkmark between the Laptop and Base Station icons shows communication has been established.</p>	

Click the **Pick Well** button and select the well by double-clicking on the well name or by clicking the **Load** button.

If the well information does not exist, create a new well by clicking the **Create** button and entering well name and information.

You **MUST** pick a well before you can choose a test module (i.e. Liquid Level or Dynamometer), or before you will see any sensors appear in the Sensor Bar across the top of the screen.

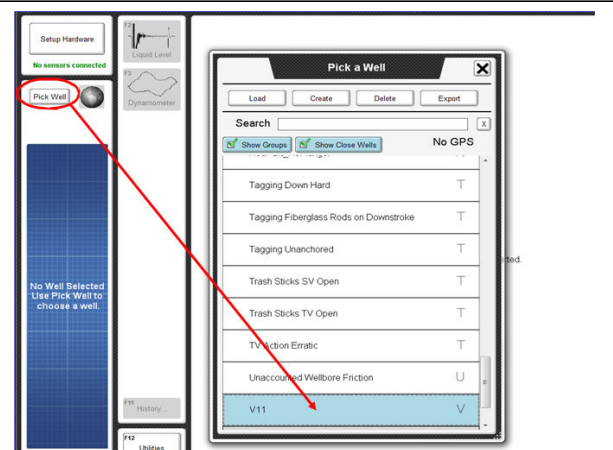

Attach the Echometer Wireless Remote Fire Gas Gun to the Well.

1. Check the threads on the wellhead valve for corrosion, wear, or damage.
2. Apply Teflon tape or paste the Mic Protector collar to prevent galling of threads.
3. For 2" NPT make 4 ½" turns for a SAFE connection to the Wellhead.
4. The working pressure of the gas gun is 1500 PSI. Do not install the gas gun on wells with pressures in excess of 1500 PSI.



Fill the gas gun volume chamber with compressed N2 or CO2 Gas.

1. The gas gun volume chamber is filled with compressed gas.
2. The pressure gauge on the volume chamber is used to determine when the volume chamber is filled to the desired pressure ABOVE the existing casing pressure.

(Note: 150 PSI – 200 PSI above the casing pressure is the recommended starting point. More or less pressure may be required depending on fluid level depth and well conditions.)



Prepare the gas gun to perform a Zero Offset on the Pressure Transducer in the gun.

1. The wellhead valve between the gas gun and the annulus should still be closed.
2. Open the bleed valve on the gas gun to bleed pressure between the casing valve and the gun before obtaining the Set Zero Offset.
3. The Zero Offset should be performed to atmospheric pressure – no wellhead pressure should be applied to the pressure transducer at this point.



Press the **Power** button to turn on the gas gun.

Counting the rapid flashing LEDs will provide the percentage of battery life remaining.

(Ex. 6 flashes = 60% power remaining)

Return to the laptop to verify communication between the WRFG and TAM.



TAM will detect the gas gun once it is powered on.

The number of sensors connected will appear under the **Setup Hardware** button in the software.

NOTE: For best signal detection and to cut down on signal interference, the larger antennae should be used on the Wireless Remote Fire Gas Gun. See more on Signal Interference in the Troubleshooting section of this manual.

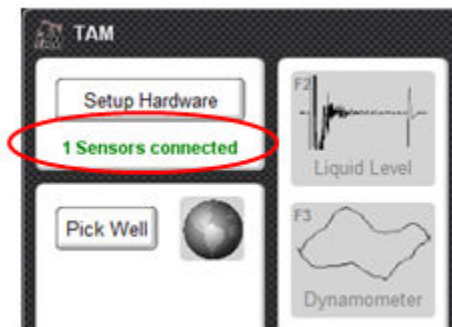

Select the Liquid Level module by clicking on the Liquid Level button or pressing F2.

Note: If the Liquid Level button is greyed out, click on Pick Well and make sure a well has been selected. A well must be selected first before the sensors will appear in the Sensor Bar.

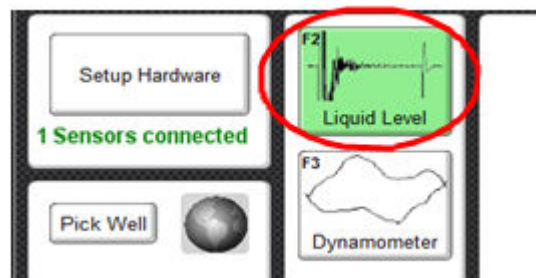

In the Sensor Bar, a Wireless Remote Fire Gas Gun icon and information is displayed.

1. A green checkmark is displayed next to the icon inside the box when there is communication with the gas gun.
2. The S/N should appear as WRFG XXX.
3. Battery power displays percent battery power remaining.
4. Signal strength is displayed as green bars above the battery percentage.

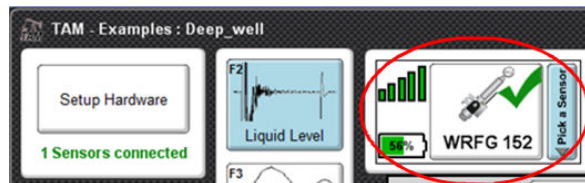

In the event the Wireless Remote Fire Gas Gun is not appearing in the Sensor Bar, click the Setup Hardware button. If the WRFG appears in the "Other Sensors" column, click the box to highlight the sensor, then click the left arrow to move it to the "My Wireless Sensors" column.

The WRFG should now appear in the Sensor Bar.

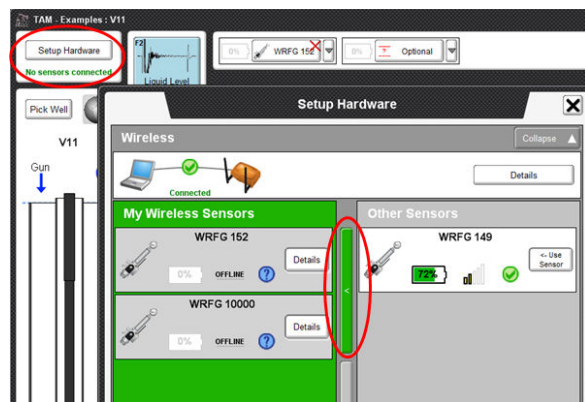

If the correct sensor icon and serial number are still not displayed in the Sensor Bar, and multiple sensors have been used or are being used (i.e. Multiple Wireless Guns being used with one laptop), it may be necessary to click the **Pick a Sensor** button and choose the correct sensor serial number.

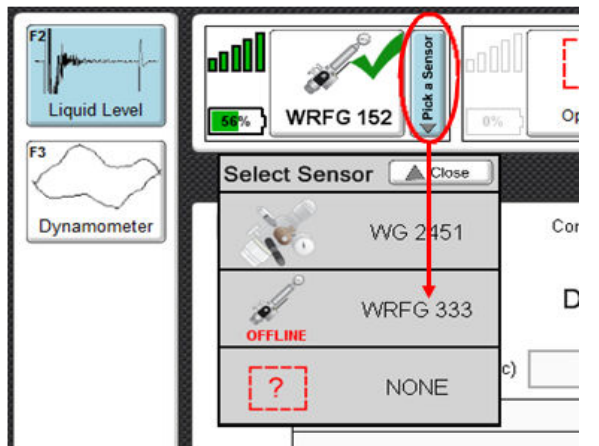

Zero the Pressure Transducer.

To Zero the Pressure Transducer inside the gun, access the **Sensor Details** screen by either clicking on the WRFG icon in the Sensor Bar,

Or

Click the **Details** button for the gun in the **Setup Hardware**.

Sensor Details Tabs:

- 1) A Zero Offset is performed on the Zero Offset tab,
- 2) The pressure transducer coefficients can be found on the Coeff tab, and
- 3) A Sensor communication check can be performed on the Sensor Check tab. The current Sensor Firmware is also displayed in the Sensor Check tab.

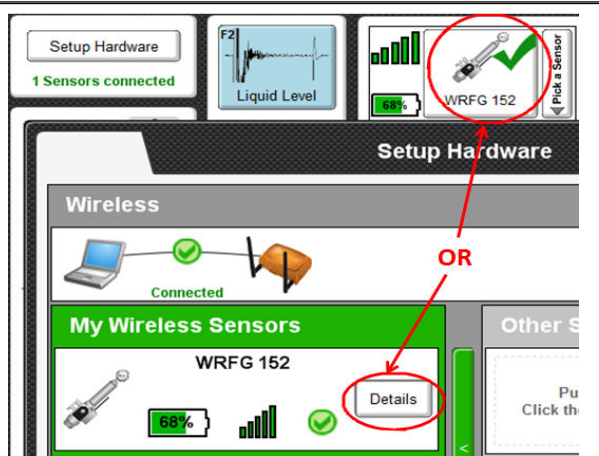

In the **Sensor Details**, click on the **Zero Offset** tab, and click the **Get New Offset** button to perform a Zero Offset on the pressure transducer in the gun.

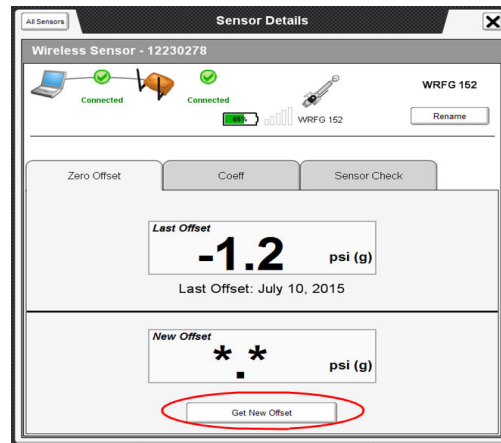

When the New Offset value is displayed and settles, click the **Use Shown Value** button to update the Last Offset date to the current date and offset value.

The New Offset box also displays a sensor temperature. The temperature value should be verified and is an excellent quality check on the sensor.

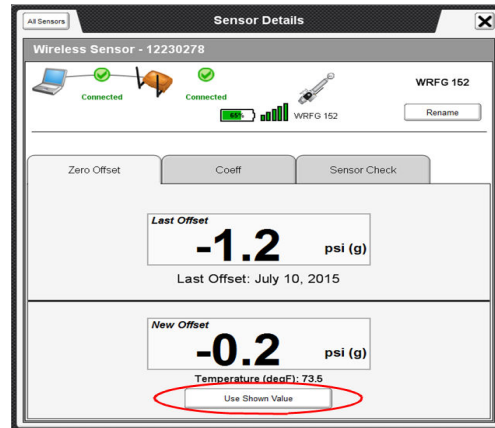

When the Zero Offset is complete and the current offset value has been saved, the Last Offset box should show the current offset value just obtained. The current date should be displayed underneath the value as the Last Offset date.

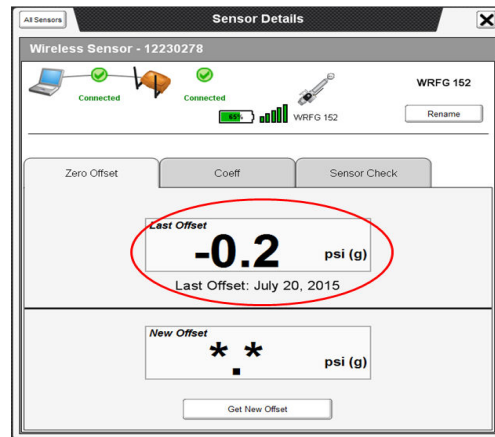

Start New Test:

A new test can be started two ways:

- 1) Click the **Start New Test** button in the TAM software, or
- 2) Return to the wellhead and press the **Acquire** button on the Wireless Remote Fire Gas Gun.

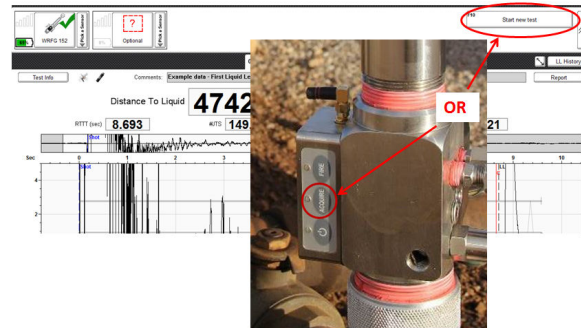

Prepare to shoot a Fluid Level.

Prepare to Acquire a shot by following the checklist displayed on the Shot Ready screen:

- 1) Charge the gas gun.
- 2) Close the gas gun bleed valve.
- 3) Open the casing valve between the gas gun and the well.
- 4) Close the casing valve to the flow line.

Both the graph and the noise level bar are displaying background noise. Inspect the well noise displayed on the screen to verify proper instrument operation and well conditions.

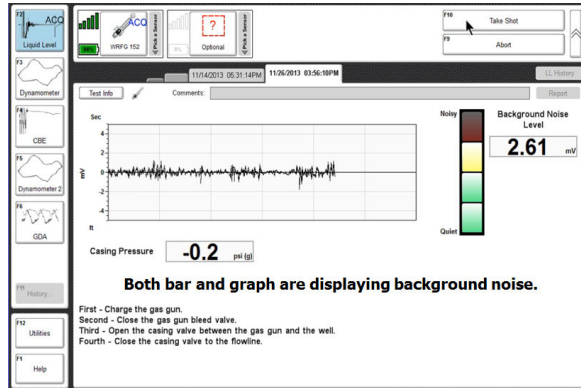

Steps to Prepare Gun to Shoot a Fluid Level:

1) Charge the Gas gun.

Charge the gas gun volume chamber to 150 – 300psi above the estimated casing pressure.

The Wireless Remote Fire Gas Gun is intended for use only in explosion mode. Charging the volume chamber above the well pressure prevents debris from entering the gas gun volume chamber and valve assembly. Debris could cause corrosion and wear to the gun.





Steps to Prepare Gun to Shoot a Fluid Level:

2) Close the gas gun bleed valve.

Failure to close the gas gun bleed valve will cause discharge of the well fluids when the valve between the gun and the casing is opened. This must be avoided.

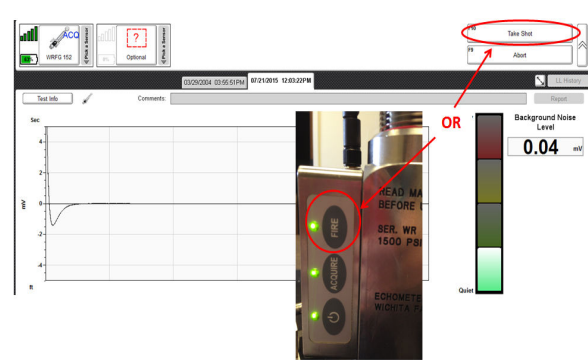

<p>Steps to Prepare Gun to Shoot a Fluid Level:</p> <p>3) Open the casing valve between the gun and the well.</p>	
<p>Steps to Prepare Gun to Shoot a Fluid Level:</p> <p>4) Close the casing valve to the flow line.</p> <p>Closing the casing valve allows the casing pressure to begin building for the pressure buildup measurement.</p> <p>Closing any other valves also isolates the path between the gas gun and the well, which cuts down on additional background noise interference with the acoustic reflections.</p>	
<p>Fire the Shot</p> <p>The shot can be fired by one of two ways:</p> <ol style="list-style-type: none"> 1) Click the Take Shot button in the TAM software. 2) Press the Fire button on the Wireless Remote Fire Gas Gun. <p>Note: Once the Start New Test or the Acquire button has been selected, the shot cannot be fired until either the Fire button LED on the gun is full on green (not blinking), or the Take Shot button is highlighted on the screen. During this approximate 13 second period, the solenoid driver is charging up to fire the shot. See the Troubleshooting Guide in this manual for more details</p>	

TAM Acquisition of Shot Fired

Once the shot is detected, the message “Acquiring Shot” is displayed. Shot data is acquired for a predetermined number of seconds based on the well depth entered in the Well File.

If the Liquid Level is identified before the software stops the acquisition, the **Shot Complete** button may be pressed to stop the acquisition. The shot is automatically saved.

Note: If the shot pulse was not detected after the gun was fired, press the Abort button (to stop acquisition of the shot data), recharge the gun to a higher differential pressure and start the test again.

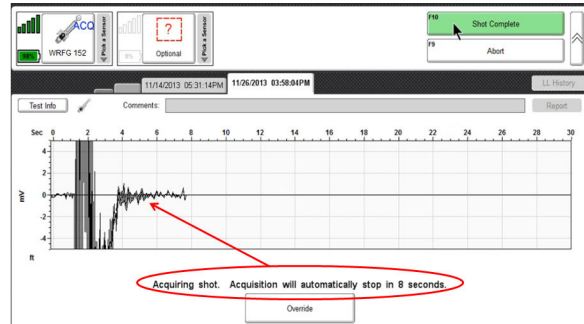

Pressure Buildup Measurements

Once the acoustic acquisition is complete, the shot is automatically saved.

TAM continues to acquire casing pressure measurements every 5 seconds for a maximum of 15 minutes or until manually stopped.

Typically, a 2 – 3 minute pressure buildup is sufficient.

Click **End Pressure Buildup** to end the test.

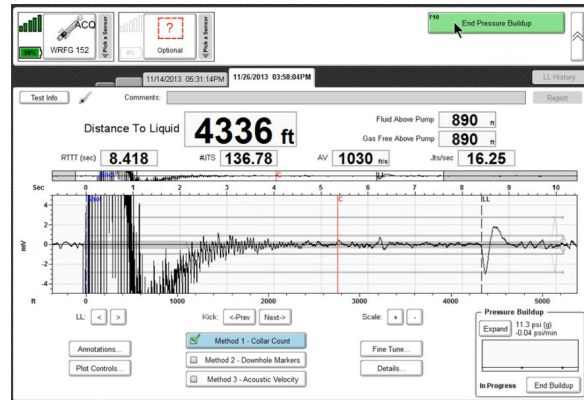

Verify Shot Details

Shot details can be verified or corrected by clicking the **Details...** button in TAM.

Pulse Type → Explosion
 Shot Path → Casing
 Well State → Producing

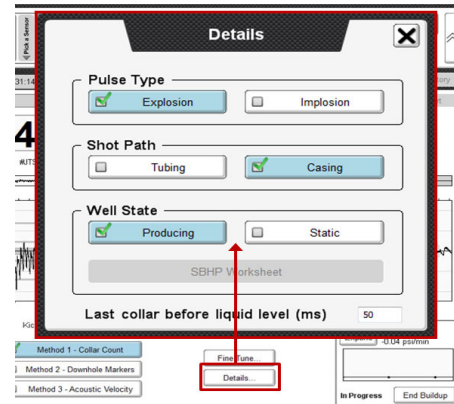

When finished obtaining acoustic tests:

1. Close the wellhead valve between the gas gun and the well.
2. Open the casing valve to the flow line.
3. Open the WRFG bleed valve to bleed off any pressure between the wellhead valve and the gas gun. Use caution if in an H₂S environment.
4. Remove the WRFG from the wellhead in the reverse order in which it was installed.

Maintenance and Troubleshooting Guide for the Wireless Remote Fire Gas Gun (WRFG)

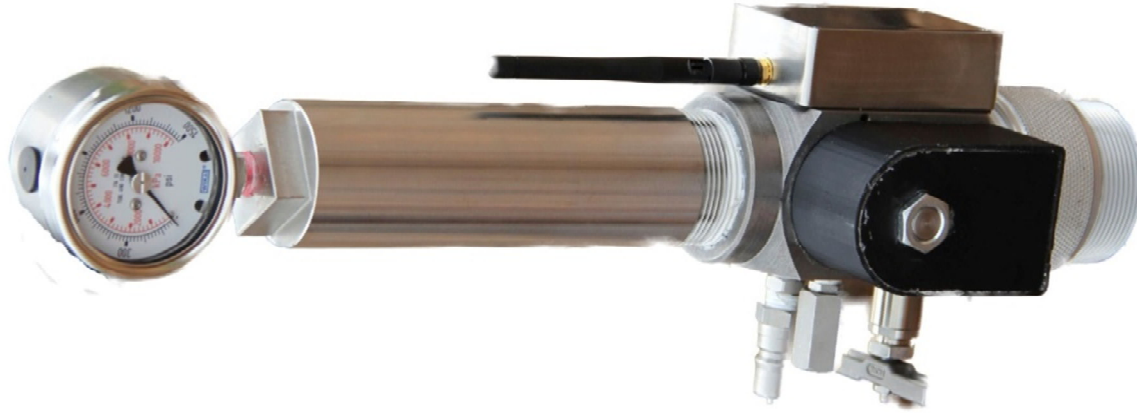

Recommended Operating Procedures to Minimize Wireless Remote Fire Gun Equipment Maintenance

1) Charge the gas gun volume chamber to a pressure in excess of well pressure.

When the wireless remote fire gas gun is placed onto the well, charge the gas gun volume chamber to a pressure in excess of well pressure before opening the casing or tubing valve.

The remote fire gas gun utilizes a solenoid with a small dart valve and a small orifice. The dart valve releases gas from behind a ½ inch moveable piston that allows gas from the gas gun volume chamber to flow into the well. These small moving parts will become clogged and inoperable if sand and debris are blown from the well into the gas gun volume chamber. Debris and sand will prevent the gas valve from properly sealing, and gas will bleed continuously from the gas gun volume chamber into the well. This requires that the gas gun be disassembled, cleaned and reassembled following the maintenance procedure discussed in the following section.

The gas gun volume chamber should be charged to a pressure in excess of well pressure with CO2 or nitrogen gas to close the gas valve and prevent well gasses and debris from the well being blown into the gas gun volume chamber. When the remote fire gas gun is placed onto the well, charge the gas gun volume chamber to a pressure in excess of the well pressure before opening the casing valve. Charging the gun will close the gas valve and prevent debris from being blown into the gas gun mechanism, resulting in more frequent maintenance.

2) Protect the remote fire gas gun housing threads from corrosion.

The threads on the gas gun microphone protector can become damaged or corroded. Protect the threads by applying thread tape, such as Teflon tape, when installing the gas gun on the wellhead. When the gun is not in use, apply a light coating of grease or oil and place a plastic cap on the threads. The pressure rating of 1500 psi will be reduced if corrosion or worn threads exists. A corrosion protective coated steel 2" 11 ½ V male to female adapter (mic protector) is available for protecting the gas gun threads and microphone. The mic protector is supplied with new remote fire gas guns. The mic protector should be installed and replaced as needed.

3) Do not fill the gas gun with liquid CO2.

To prevent liquid CO2 from entering the gas gun, the CO2 cylinder should be held upright so that gas at the top is discharged from the cylinder into the gun instead of liquid CO2 from the bottom of the cylinder.

Occasionally, the valve core inside the filler connector housing can stick open and blow CO2 gas back out of the filler connector housing and into the atmosphere. The gas leakage can be caused by liquid CO2 freezing the valve core, as it is discharged into the gas gun volume chamber. Filling the gun with gas instead of liquid CO2 will prevent freezing and sticking of the valve core.

4) Keep debris out of the filler connector housing.

To help prevent debris from entering and clogging the filler connector housing, keep the filler connector on the CO2 hose from becoming clogged with dirt and debris. Do not allow the cylinder hose to drag through the dirt.

If debris in the valve core filler connector housing causes the gas gun to leak, lubricate the valve core with light oil. Remove the filler connector housing and add light oil directly onto the valve core. Install the filler connector housing and then refill and discharge the gas gun with CO2 a few times. Firing the gun multiple times will remove the debris from the valve core. Be sure that the valve core is properly tightened while the filler connector housing is removed.

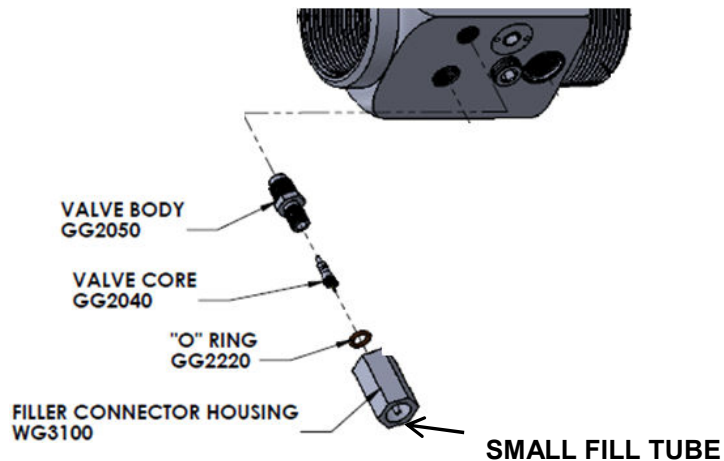

5) Replace filler connector housing if small fill tube is damaged.

A worn or bent or flattened small fill tube (see illustration above) in the filler connector housing prevents the CO2 gas from being released into the gas gun volume chamber. The solution is to replace filler connector housing.

Wireless Remote Fire Gas Gun Maintenance Procedures

Solenoid Assembly Dart Valve Maintenance

Clean the dart valve if gas is constantly leaking from the relief hole located on the gun body between the solenoid and electronics housing.



If chamber pressure is not holding and gas is constantly leaking out the small pressure relief hole located on the gun body between the solenoid and electronics housing, then probably the dart valve inside the solenoid assembly is not sealing, allowing pressure to leak out the pressure relief hole.

The solution is to carefully disassemble the solenoid and clean the dart valve assembly. An instructional video is included on the USB flash drive or available for download from www.echometer.com/Support/MaintenanceGuides. Please view the instructional video before attempting to do the following procedure.

- 1) Use the spanner wrench provided with the solenoid repair kit to remove the nut securing the Solenoid Housing and use your hand to carefully ease the Solenoid housing up and over the plunger housing. **The solenoid has been wired to electronics inside the gun. Do not pull or break the wires.**
- 2) Remove the flux washer that fits on the bottom of coil housing and again use the spanner wrench to unscrew the plunger assembly from the housing.



- 3) When removing the plunger housing, be careful to not drop the plunger spring or dart valve and plunger. The dart valve is the little plastic needle inside of the plunger. You should visually examine the dart valve tip for any debris. Any debris can prevent the dart valve from making a gas tight seal in the dart valve seat; just a grain of sand, a small metal shaving, or other debris can get between the dart valve and seat and prevent an airtight seal. The debris will allow pressurized gas to leak past the dart valve and out of the vent. To clean the dart valve wipe the tip with a soft clean cloth or in the field your finger will normally work ok. Once the dart valve is clean, then carefully reassemble the solenoid assembly.

If the dart valve tip is damaged, then it must be replaced. The dart valve can be removed from the plunger. Then replace the dart valve with new valve (included in the solenoid repair kit) and reassemble the solenoid assembly.

- 4) After cleaning the dart valve, the dart valve seat should be inspected. The dart valve seat sits just underneath the dart valve plunger assembly and is held in place with an O-ring. The seat can be removed and there could be debris lodged inside the seat. Spray contact cleaner through the dart valve hole and through the two slots on either side of dart valve seat. The spray will purge all debris and clean the hole. The O-ring on the dart valve seat should be free of cuts and abrasions. After the seat is inspected, replace and lubricate the O-ring on the dart valve seat. Then carefully reassemble the solenoid assembly and tighten with the spanner wrench.

Gas Valve Maintenance

Replace the O-ring on the gas valve (WG1800), if gas is leaking from the bottom end of gun.

The symptom of gas pressure bleeding past the gas valve and leaking out the bottom end of gun, or leaking into the well, is shown by the pressure gauge not building or holding a positive pressure.

Most likely the problem is caused by the smaller of the two O-rings (WG-1750) on the gas valve being cut. The cut in the O-ring is allowing gas pressure to flow past the O-ring and into the well.

The solution to repair this problem is to remove the gas valve and replace the O-ring. Please view the instructional video included on the USB flash drive, or download the video from www.echometer.com/Support/MaintenanceGuides.

The following steps should be taken to check the O-rings on both the gas valve and the orifice:

1. Remove the volume chamber to expose the orifice and the orifice housing,
2. Remove the orifice housing with a 7/8 inch socket wrench,
3. Use the repair kit's 6-32 machine screw to screw in the top of the gas valve,
4. Pull the gas valve from the housing.
5. Inspect the small O-ring on the bottom side of the gas valve for cuts or mis-shape. The smaller of the two O-rings does most of the work and most of the sealing, because it fits in a hole in the bottom of the housing and seals off the chamber. The gas valve is continuously working up and down as the gun is fired, so the small O-ring takes a lot of wear and tear.
6. When the gas valve is removed, O-ring lubricant or bearing grease should be applied to the O-rings. The lubrication helps the gas valve to slide more freely and lengthens the life of the O-rings.
7. Inspect the WG-1600 O-ring on the bottom side of the orifice housing and replace if the O-ring is cut or if it is worn. Failure of the WG-1600 O-ring can prevent the orifice from functioning properly, allowing gas pressure to bypass the orifice and leak underneath the orifice housing into the gas valve chamber. This type of leak prevents gas pressure from being bled off from the topside of the gas valve rapidly enough for the gun to fire properly.

Lubricate O-rings on the moving gas valve.

Put a little bit of lubricant inside the volume chamber as well. Make sure the chamber inside the gun is clean where the gas valve actually operates. A build-up of gunk or debris inside the volume chamber can prevent that gas valve from moving freely and the gas valve has to move freely to work properly.

Do not wait for long periods between maintenance of the gas valve. The remote fire gun should be taken apart, cleaned and O-rings should be re-lubricated every 3 months. Lack of proper maintenance will allow the O-rings to become dry and friction can actually stick the gas valve inside the gun and will not allow the gun chamber to charge. If excessive pressure is required to charge the remote fire gas gun, the gas valve probably needs to be lubricated.

If a pressure build-up test is to be performed on a well, the recommended practice is to inspect both the dart valve and gas valve before the start of the test.

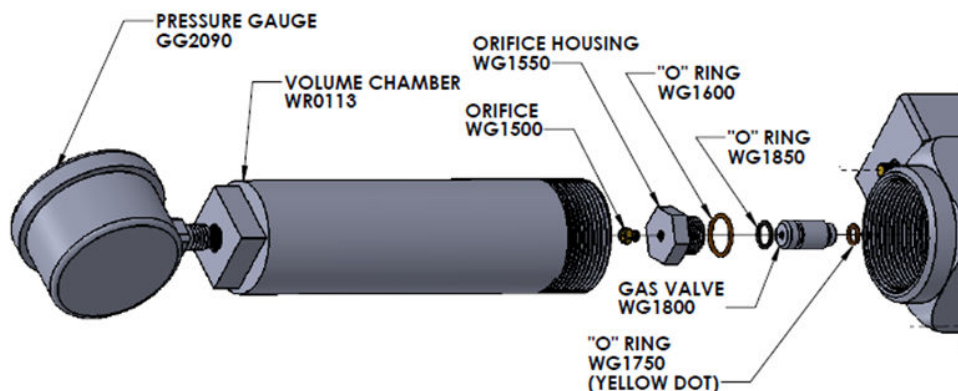

Orifice Housing Maintenance

Clean the orifice and orifice housing if they become clogged.

The orifice has a 0.015" hole through its center and it is screwed into the orifice housing. The orifice and the orifice housing need to be cleaned if clogged with debris that restrict the flow of gas into the volume chamber.

The orifice and orifice housing are cleaned by first removing them from the gun, then spraying WD 40 or a pressurized electrical contact cleaner through them. The orifice is removable and can be replaced with a new one, however the orifice is normally reliable and trouble free.

Microphone Care and Maintenance

The microphone cannot be repaired in the field, do not disassemble. If fluids enter the microphone, the microphone will be damaged.

Saltwater will cause immediate failure of the microphone if it is allowed to enter the inside of the microphone. Clean the lower threaded portion of the remote fire gas gun after each day's use with a mild cleaner such as soapy water, alcohol, WD 40 or a pressurized electrical contact cleaner which can be obtained from an electrical supply store. Coat the inside of the gas gun lower chamber with grease or a light coating of oil.

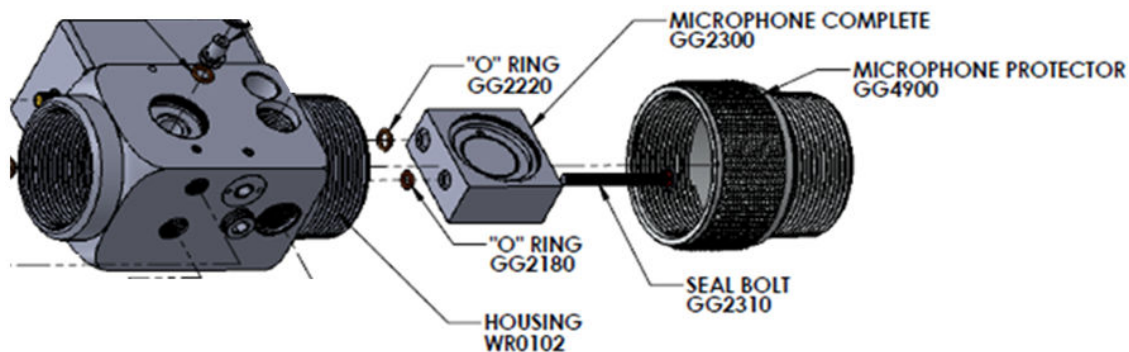

If the microphone is removed from the gas gun, be sure to clean the lower portion of the gas gun thoroughly and also the microphone before attempting to reinstall the microphone into the lower chamber. If the microphone is removed from the gas gun, always replace the O-ring (Part No. GG2220) with a new O-ring that fits over the electrical connection between the microphone and the remote fire gas gun. Be sure to lubricate the O-ring with an O-ring lubricant, grease or oil.

Cleaning

When wells are chemically treated from the surface, the Echometer gas gun should be cleaned at the end of each day.

The gun and microphone are constructed from stainless steel and the microphone has Mylar plastic coatings. Almost all hydrocarbon oils and water will not damage the microphone. Some wells are chemically treated at the surface for corrosion. High concentrations of some chemicals are corrosive and will cause corrosion to the stainless steel Echometer gas gun parts. If the wells to be acoustically tested are chemically treated at the surface, the Echometer gas gun should be cleaned at the end of each day because the chemical may be corrosive to gas gun parts.

To clean the gas gun, first, pressurize the gas gun. Then use a hydrocarbon solvent, soapy water, alcohol or household cleaning agent to clean the portion of the gas gun that is exposed to well gases. Allow parts to drip dry or blow dry with compressed gas.

Recommendations for Cleaning the Wireless Remote Fire Gun – Do’s and Don’t’s

- Never submerge your wireless equipment in any form of liquid.
- DO NOT use brake cleaner on your wireless equipment.
- DO NOT use carburetor cleaner.
- DO NOT use B-12.
- Use an Electronics Cleaner Degreaser sprayed onto a rag, then wipe the equipment down with the rag. DO NOT spray directly onto the electronics housing, the antenna, or the membrane switch (where the Power, Acquire and Fire buttons and their corresponding LEDs are located).

To download a video of the wireless remote fire gun being disassembled for maintenance, please visit www.echometer.com and click on the Support tab, Maintenance Guides.

REMOTE FIRE WIRELESS GUN

EQ1125 REV A

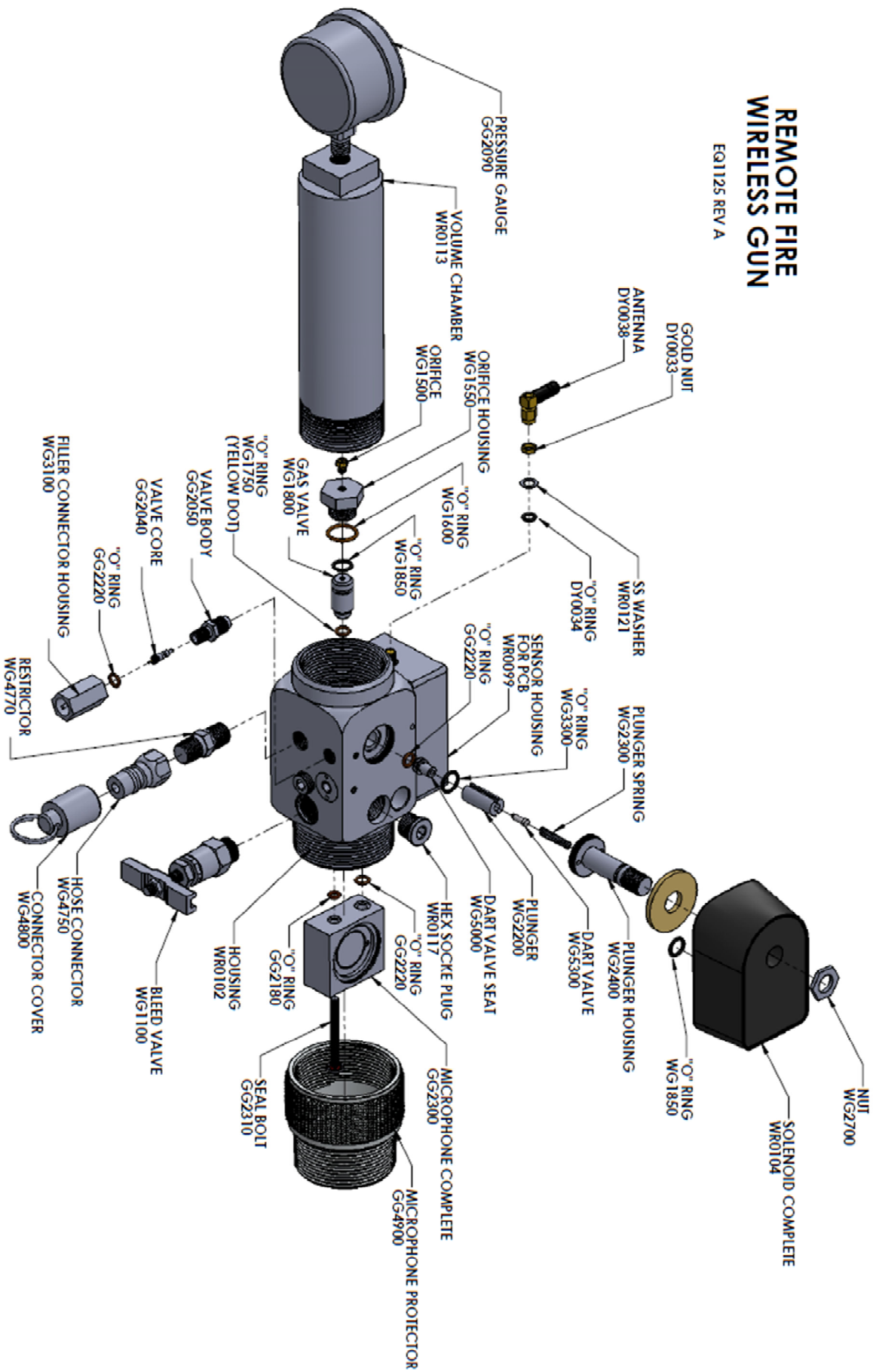

Troubleshooting Proper Sensor Function (WRFG)

In order to troubleshoot problems occurring during fluid level acquisition, it is important to understand how the sensor should be behaving and interacting with the base station and TAM software before, during and after acquisition.

Prior to Shot Firing

The Base Station should be connected to the laptop. Both the Power and Status lights on the Base Station should be flashing green [1]. They may not all be flashing in sync which is okay.

The WRFG Power light should be flashing green [2]. If the sensor is in fast beacon mode, the light will flash approximately every half second. If the sensor has been sitting for five minutes without any activity, the sensor will go into slow beacon mode and the power button will flash approximately every 4-5 seconds.

Below the Setup Hardware button, the number of sensors connected should be displayed [3]. For a Liquid Level shot, a WRFG image with the correct serial number should be displayed in the Sensor Selection bar. The sensor should be active, indicated by the green checkmark within the box and also the signal and battery readings [4].

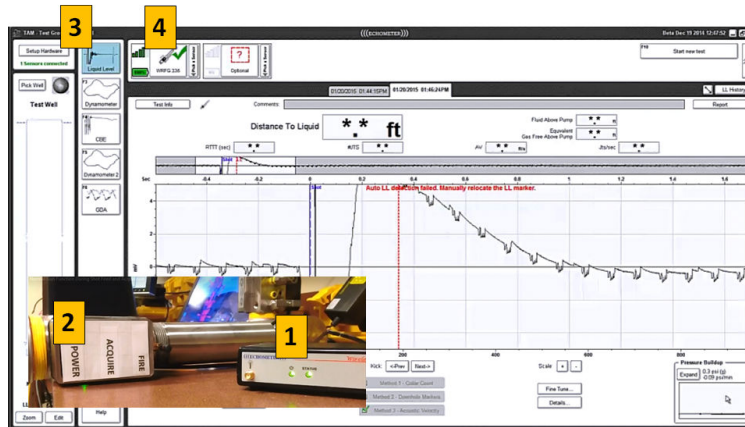

Shot Firing and Acquisition of Acoustic Trace

When the **Start New Test** button is clicked, the Base Station will send the command to the WRFG. The Acquire light on the WRFG will begin flashing green as the screen changes to the acquisition screen.

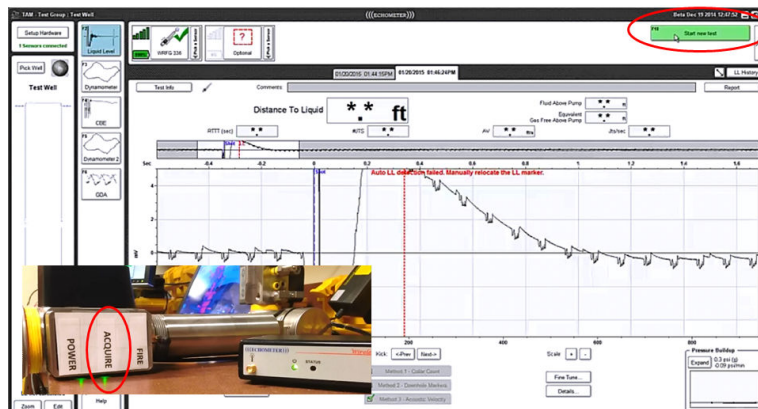

On the Acquisition screen, while the **Take Shot** button is grayed out, the Fire light on the gun will begin blinking. During this period, all three button lights will be flashing green.

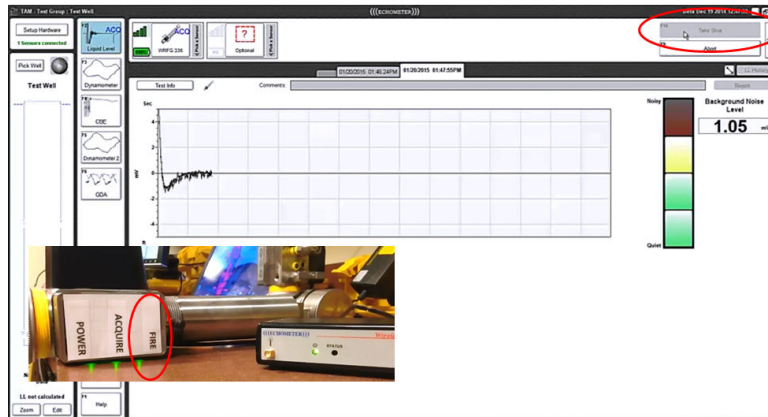

It will take approximately 13 seconds for the solenoid to charge and become ready to fire. Once the solenoid is charged and the **Take Shot** button becomes available to click on the screen, the WRFG Fire button light will remain on steady green until the **Take Shot** button is clicked on the screen, or the **Fire** button is pressed on the WRFG. The Power and Acquire lights will continue flashing green.

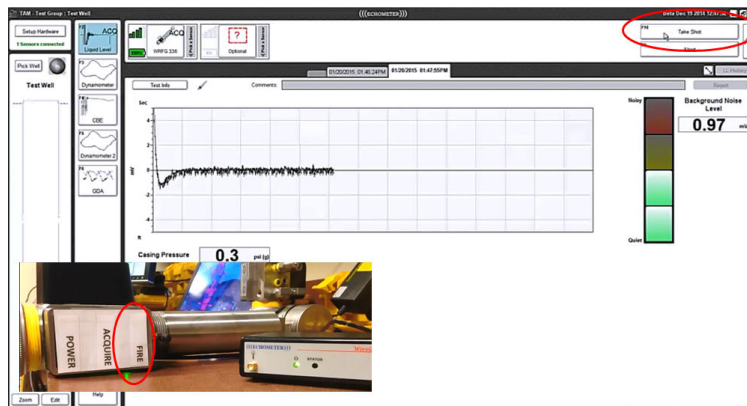

Once the acoustic pulse has been fired, the WRFG **Fire** button light will turn off. The Acquire and Power lights will continue flashing green. When the desired liquid level shot is obtained, click the **Shot Complete** button, or allow the software to end acquisition of the shot automatically.

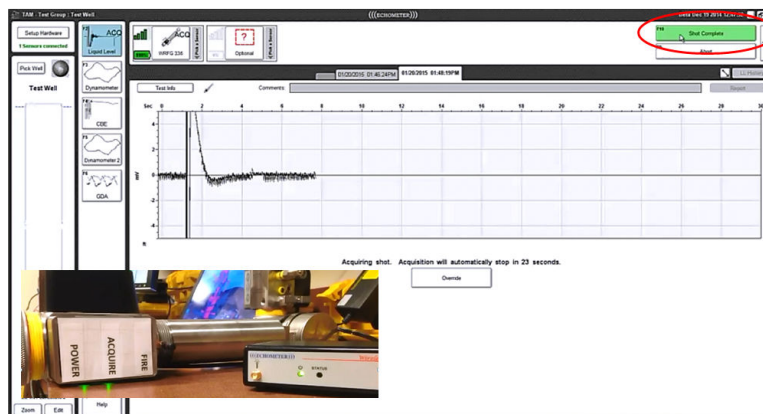

The Power and Acquire lights will continue flashing as the pressure buildup data is being recorded and until the **End Pressure Buildup** button is clicked.



Once Acquisition has Ended

Once the **End Pressure Buildup** button is clicked, the Acquire light will go off and only the Power light will continue to flash.

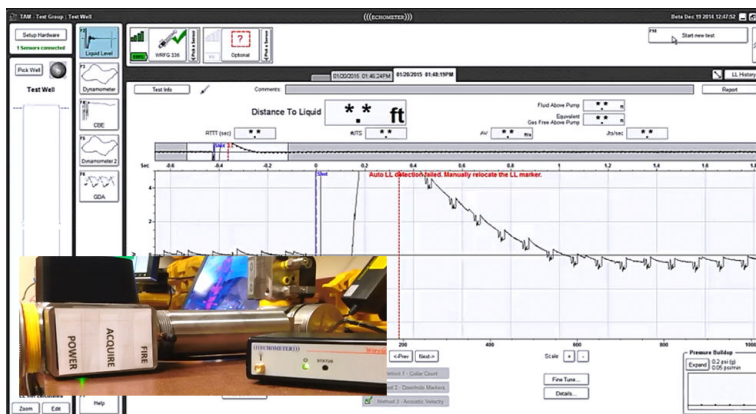

Troubleshooting LED Behavior on Sensors or Base Station

When the equipment is not functioning properly, or there is a problem with the sensor or sensor communication, the LED lights above the Power, Acquire and Fire buttons will give an indication of the problem.

- 1) Upon initial Power- on of the sensor, the normal light sequence is as follows:
 - The green Power light will flash, followed by the Acquire and Fire green lights shortly afterwards so that all three green lights are illuminated.
 - Next, all three lights will flash red once.
 - The Power light will then flash rapidly in green. Counting the rapid flashes will give a percentage of remaining battery power. (Example: 2 flashes = 20%, 8 flashes = 80%)
 - Finally, the Power light will begin flashing in fast beacon mode approximately every half second. It will continue to flash in this manner until 5 minutes has passed with no commands from the Base Station. After 5 minutes the sensor will go into a slow beacon mode and the rate of flashes will drop down to once every 4-5 seconds.
Note: Signal strength is not displayed on the screen if the sensor is in slow beacon mode.
- 2) If, when the sensor is powered on, the lights on the sensor immediately begin flashing red, this could be an indication that the sensor did not properly boot up when the Power button was pressed.
 - The operator should press the Power button for 2-3 seconds to power down the sensor, and then press the Power button again to initiate the power up cycle.
 - After a few attempts, if the LEDs continue to flash red, contact Echometer or send the sensor in for further investigation by Echometer technicians.

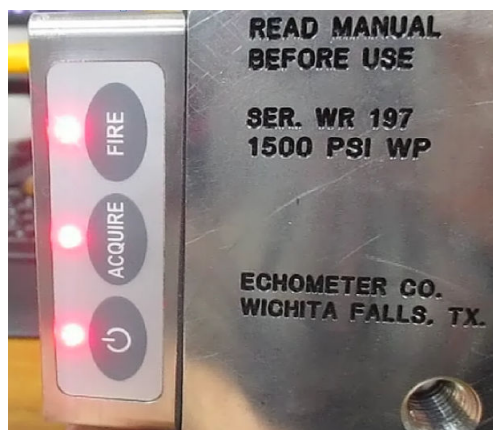

- 3) Once the **Start New Test** button has been clicked on the laptop, the Power, Acquire and Fire lights will all begin flashing green. When the TAM software displays a white **Take Shot** button, the Fire light will be full on until either the Take Shot button is clicked in the software, or the Fire button is pressed on the gun itself.
If the Fire light is “stuck on” and the shot cannot be fired from the software or the gun, it could be due to:
 - Bad communication between the TAM software and the Base Station.
 - The Base Station Status light is flashing red, and the Fire light is full on.
 - The TAM software may have frozen and is not sending the command through the Base Station to the gun.
 - The gun has had a glitch and is not responding to commands from the TAM software or manually.

An operator observing the previously described behavior can take the following steps:

- Press the Power button on the WRFG for 2-3 seconds to power down the sensor. Then restart the power up cycle and observe the proper booting up light sequence.
- The Base Station should be reset if needed by unplugging the USB cable from the laptop and plugging it back in. If a red Status light remains after resetting the Base Station, contact Echometer for further instruction.
- If the problem initiated in the TAM software resulted in a software “crash,” please take the steps to report the crash to Echometer so that an investigation can be performed. All crash reports sent to Echometer are reviewed and considered for further action and improvement to the TAM software. Crash reports are sent to Echometer when the laptop is connected to the internet.

- 4) During the approximately 13 seconds after the **Start New Test** button has been clicked, the **Take Shot** button will be greyed out. Once the capacitor has charged enough to fire the gun, the sensor notifies TAM there is ample power to fire the gun, the **Take Shot** button will turn white, and the operator can then fire the shot.

If the **Take Shot** button remains greyed out and does not allow the gun to be fired, the operator should consider the following:

- Check that the battery power on the WRFG sensor is above 30%. If the battery power is getting low, it may not have enough power to fully charge the capacitor, or
- The capacitor may not be reaching the voltage TAM is expecting. The operator should recharge the battery in the WRFG and attempt the fluid level shot again.
- If the battery power is good and the Take Shot button is still not allowing a shot to be fired, contact Echometer for further instructions.

- 5) In the event the TAM software has not received any response from the WRFG sensor for 3 seconds, the following message will be displayed:



An operator observing the previously described behavior can take the following steps:

- Press the Power button on the WRFG for 2-3 seconds to power down the sensor. Then restart the power up cycle and observe the proper booting up light sequence.
- The Base Station should be reset if needed by unplugging the USB cable from the laptop and plugging it back in. If a red Status light remains after resetting the Base Station, or if the perator continues to receive the error message in TAM, contact Echometer for further instruction.
- If the problem initiated in the TAM software resulted in a software “crash,” please take the steps to report the crash to Echometer so that an investigation can be performed. All crash reports sent to Echometer are reviewed and considered for further action and improvement to the TAM software. Crash reports are sent to Echometer when the laptop is connected to the internet.

- 6) If communication between the Base Station and the laptop has stopped during an acquisition (i.e. the Base Station has become unplugged, the cable is bad, or the USB port has failed), the gas gun Acquire light may turn red.

If the TAM software senses lost communication with the Base Station during acquisition, the following message will appear on screen at the same time the WRFG sensor Acquire button begins flashing red:



If this situation occurs:

- Make sure the USB cable is securely attached between the Base Station and the laptop.
- Unplug the Base Station and plug it back in to reset it.
- If the Power and Status lights are both green (the Status light should always be flashing green), restart the test and begin acquisition again.
- Reset the WRFG by holding down the Power button for 2-3 seconds. Restart the gun and make sure proper booting sequence occurs.

Troubleshooting Interference or Poor Sensor Signal

An operator working in a field with a high level of radio frequency signal traffic may experience interference between their sensors and Base Station. This will be evident by a poor signal reading on sensors and possibly poor data acquisition or lost communication during acquisition.

- 1) Two different antenna lengths are provided with each wireless remote fire gun. If problems arise with signal strength or interference, the longer antennas should be installed on both the W5KG and the Base Station.
- 2) Make sure the Base Station is within line of sight of the sensor. Don't mount the Base Station under or behind a vehicle seat.
- 3) The Base Station channel can be changed within the TAM software to find a clear channel for better communication between the sensor and the Base Station.

Take the steps on the following page "[Steps to Change the Radio Frequency Channel on the Base Station](#)" to change the radio frequency channel on the Base Station.

Steps to Change the Radio Frequency Channel on the Base Station:

Step 1 – Click the Setup Hardware button in the TAM software when the Base Station is connected. Inside the Setup Hardware screen, click the “Details” button to open the Base Station detail information.

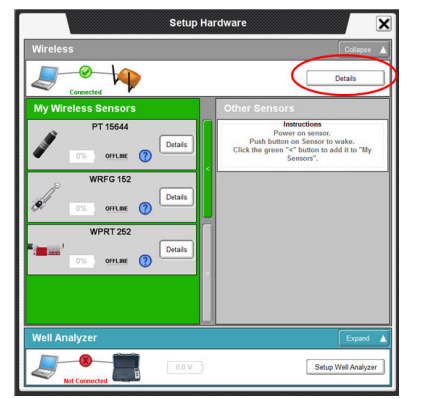

Step 2 – There are two radio channels on the Base Station for data acquisition. These two channels are what make it possible to shoot liquid levels while obtaining dynamometer data simultaneously. The default channels, as displayed below, are 15 and 25.

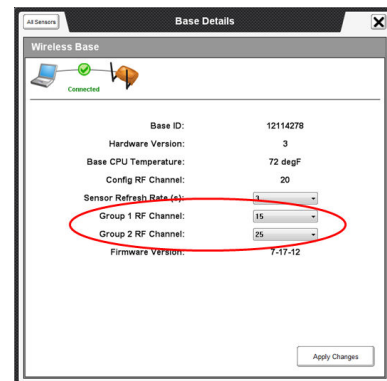

To change the Radio Frequency Channel of the Base Station, click on the dropdown box and select a different channel.

Group 2 RF Channel corresponds to the Liquid Level Channel and is used by the W5KG.

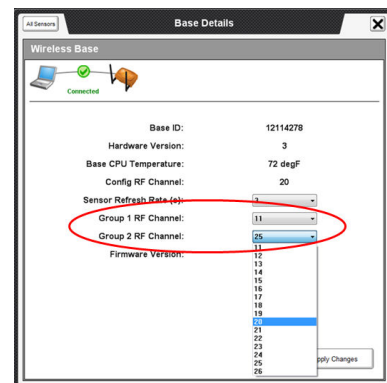

Step 3 – After selecting a different channel, click the “Apply Changes” button to save the new frequency channel selected.

If communication with the Base Station does not improve, then repeat this process of selecting different radio frequency channels until a satisfactory performance is achieved.

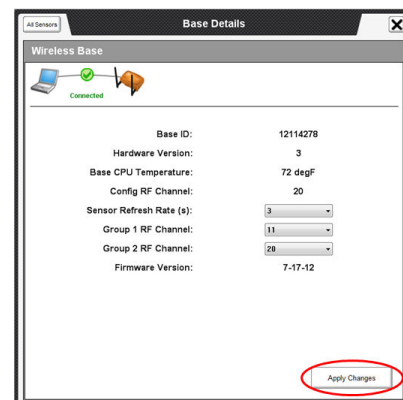

Allow TAM Software to Install/Update Device Driver for Hardware

When the TAM software is installed on a computer that will be used for acquiring data or troubleshooting equipment, make sure to click **Install** when prompted during the installation.

The Install will automatically default to "Don't Install" as seen below.

Failure to click **Install** and install the device software will prevent the software from recognizing the Wireless Base Station driver in the USB port, and the operator will be unable to acquire data using that computer.

A reinstall of the software will again prompt the user to install the driver software in the event this step is not performed on the initial install.

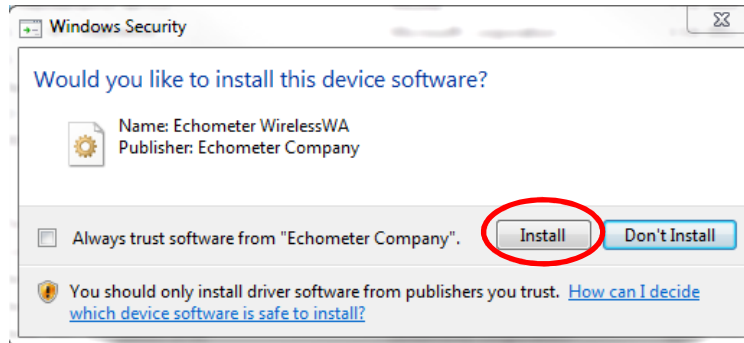

CARBON DIOXIDE CYLINDER

Echometer Part No. GG0430 & GG0470

CAUTION

DO NOT OVER FILL, fill cylinder based on weight of CO₂.

Contents under pressure.

Do not inhale gas or allow gas to touch skin. Gas becomes cold during use and can cause frostbite or other personal injury.

Metal parts of Cylinder can become extremely cold during use. Protect hands and other parts of body from direct contact with metal parts of Cylinder during use.

Contains carbon dioxide gas under pressure. Do not puncture or incinerate Cylinder. Do not expose to heat or store at temperature above 170 degrees F (76°C).

Keep out of reach of children.

See details in operating manual.

Have Cylinder hydro pressure tested or replaced five years from date of stamp.

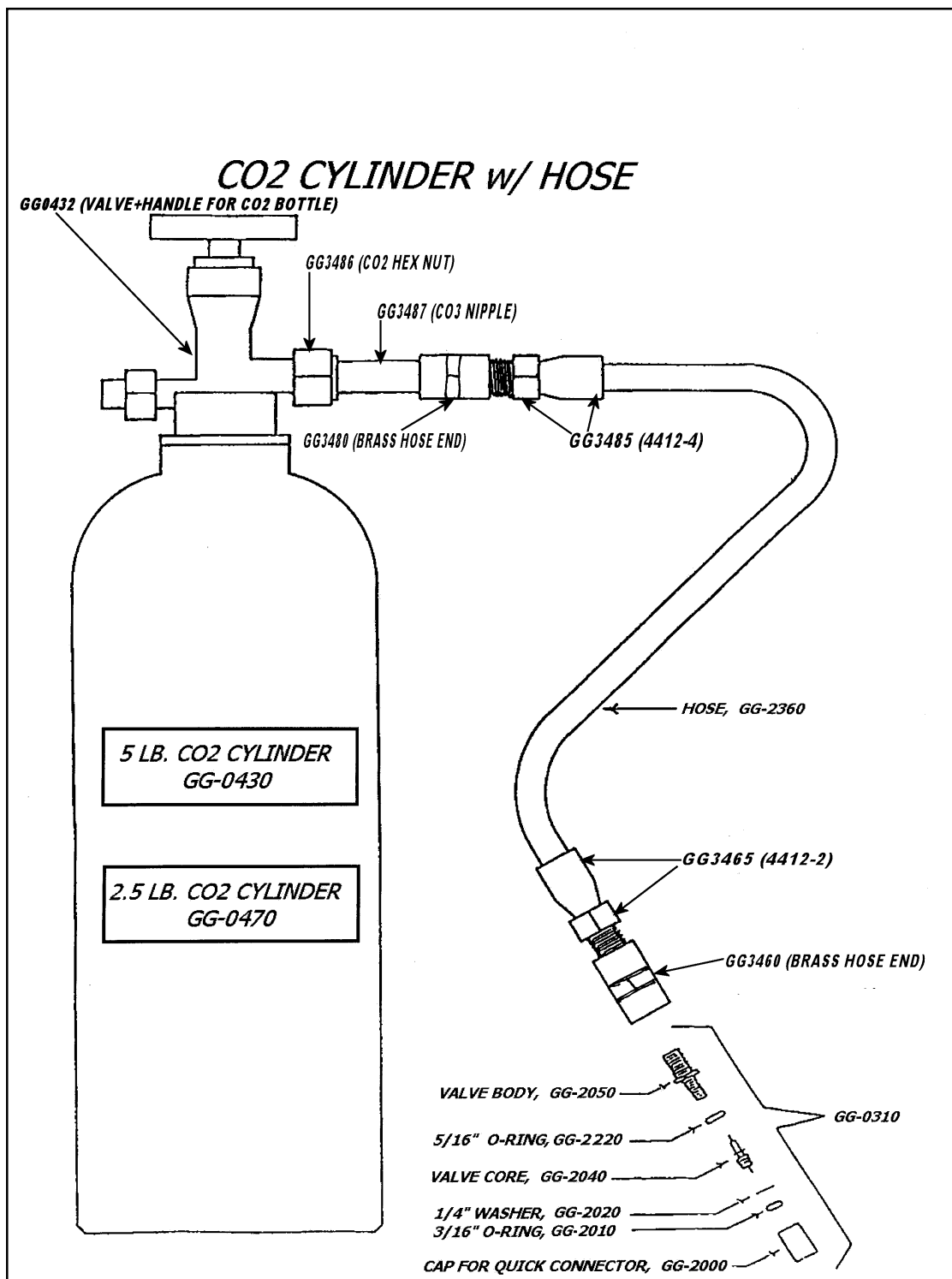

CARBON DIOXIDE GAS INFORMATION (CO₂)

Carbon dioxide is a nonflammable, colorless, odorless, slightly acid gas. It is one and one-half times as heavy as air. CO₂ is used in the carbonation of soda pop, as an inert agent in fire extinguishers, in canned food products, and many other applications.

Below 88°F, confined CO₂ liquid and gas are in equilibrium at a vapor pressure shown in the table below. For example, a Cylinder of CO₂ liquid and gas at 59°F has a pressure of 723-psia. As gas is removed from the cylinder, the liquid vaporizes into a gas, which maintains the vapor pressure shown. When all of the liquid has been vaporized, the gas pressure will reduce as gas is withdrawn. Following is a table of the vapor pressure as a function of temperature.

<u>Temperature</u>		<u>Pressure</u>	
°F	°C	PSI	Bar
88	31	1053	73
59	15	723	50
32	0	490	34
5	-15	317	22
-22	-30	192	13

Above 88°F, CO₂ becomes a fluid. Liquid does not exist separate from gas. The pressure in the tank is an indication of the amount of CO₂ present in the tank. As the gas is used, the pressure will decline. At 90°F, the pressure in a full cylinder will be approximately 1100-psi.

The amount of CO₂ in a cylinder is determined by weighing the cylinder containing the CO₂ and then subtracting the weight of the empty cylinder which is shown on the cylinder. Below 88°F, the amount of CO₂ in the cylinder cannot be estimated by measuring the pressure unless the pressure is less than the vapor pressure shown on the graph. If the pressure is less than the vapor pressure, the Cylinder does not contain any liquid CO₂ and very little CO₂ remains in the Cylinder.

CO₂ is heavier than air and may collect in confined, unventilated areas. Do not permit a leaking cylinder in a closed automobile. CO₂ is the regulator of the breathing function, and an increase in the CO₂ inhaled will cause an increased rate of breathing. In high concentrations, CO₂ can paralyze the respiratory system. Do not breathe air having excessive amounts of CO₂.

Do not overfill a CO₂ Cylinder or dangerous pressures can result. Do not use CO₂ cylinders, which show any sign of wear, abuse, corrosion, worn threads or any mishandling.

CO₂ - PHYSICAL CONSTANTS

Density, Gas @ 70°F, 1atm	0.1144 lb/cu ft
Critical Temperature	87.8°F (31°C)
Critical Density	0.468 g/ml
Critical Pressure	1072-psia (73-atm)
Specific Gravity	1.53
Specific Volume @ 70°F, 1-atm	8.76 cu ft/lb or 15,000 cu in/lb or 950 cu in/oz

NITROGEN GAS INFORMATION (N₂)

Nitrogen comprises approximately 79⁰/₀ by volume of the air. It is found chemically combined in many forms in nature. Nitrogen will not burn and will not support combustion. Nitrogen is normally available in cylinders compressed to 2200-psi.

Nitrogen is used as an inert gas in electrical systems, the chemical industry, and in the food packaging industry. Nitrogen, also finds extensive use as an inert atmosphere and in the filling of some incandescent lamps.

Nitrogen is nontoxic but can asphyxiate human beings and animal life by displacing the necessary amount of oxygen in the air to sustain life.

ACOUSTIC LIQUID LEVEL DEPTH MEASUREMENT CONSIDERATIONS

Generally, a pressure regulator should be used with N₂ since the initial cylinder pressure is 2200-psi, which is normally in excess of the wellhead pressure rating or the maximum rating of some of the pressure gauges.

During pressure buildup testing, the pressure regulator should be set so that the pressure in the volume chamber will exceed the pressure on the casing annulus when the operator returns to check the equipment. Less gas will be used if the pressure regulator is set to a lower value.

HANDLING PRECAUTIONS

Never drop cylinders or permit them to strike each other violently.

Never tamper with safety devices in valves or cylinders. See your local gas supply dealer for other precautions.

N₂ - PHYSICAL CONSTANTS

Molecular Weight	28.016
Density @ 70°F, 1-atm	0.0724 lb/cu ft
Critical Temperature	-232.87°F (-147.15°C)
Critical Pressure	492.45-psia (33.5-atm)
Specific Volume @ 70°F, 1-atm	13.812 cu ft/lb or 23,867 cu in/lb